

# \*TB 9-4931-527-40

DEPARTMENT OF THE ARMY TECHNICAL BULLETIN

## CALIBRATION PROCEDURE FOR CALIBRATION FIXTURE, HEWLETT PACKARD MODEL 11715A

Headquarters, Department of the Army, Washington, DC  
15 April 2008

*Distribution Statement A: Approved for public release; distribution is unlimited.*

### REPORTING OF ERRORS AND RECOMMENDING IMPROVEMENTS

You can improve this manual. If you find any mistakes or if you know of a way to improve these procedures, please let us know. Mail your letter or DA Form 2028 (Recommended Changes to Publications and Blank Forms) directly to: Commander, U.S. Army Aviation and Missile Command, ATTN: AMSAM-MMC-MA-NP, Redstone Arsenal, AL 35898-5000. A reply will be furnished to you. You may also send in your comments electronically to our E-mail address: [2028@redstone.army.mil](mailto:2028@redstone.army.mil) or by fax 256-842-6546/DSN 788-6546. For the World Wide Web use: <https://amcom2028.redstone.army.mil>. Instructions for sending an electronic 2028 can be found at the back of this manual.

SECTION		Paragraph	Page
	I. IDENTIFICATION AND DESCRIPTION		
	Test instrument identification .....	1	2
	Forms, records, and reports.....	2	2
	Calibration description .....	3	2
	II. EQUIPMENT REQUIREMENTS		
	Equipment required .....	4	2
	Accessories required.....	5	3
	III. CALIBRATION PROCESS		
	Preliminary instructions.....	6	3
	Equipment setup .....	7	4
	Frequency range.....	8	4
	FM distortion.....	9	5
	FM flatness .....	10	6
	Final procedure .....	11	8

\*This bulletin supersedes TB 9-4931-527-50, dated 6 January 2005.

## SECTION I IDENTIFICATION AND DESCRIPTION

**1. Test Instrument Identification.** This bulletin provides instructions for the calibration of Calibration Fixture, Hewlett Packard Model 11715A. The manufacturer's manual was used as the prime data source in compiling these instructions. The equipment being calibrated will be referred to as the TI (test instrument) throughout this bulletin.

**a. Model Variations.** None.

**b. Time and Technique.** The time required for this calibration is approximately 2 hours, using the dc and low frequency technique.

### 2. Forms, Records, and Reports

**a.** Forms, records, and reports required for calibration personnel at all levels are prescribed by TB 750-25.

**b.** Adjustments to be reported are designated (R) at the end of the sentence in which they appear. When adjustments are in tables, the (R) follows the designated adjustment. Report only those adjustments made and designated with (R).

**3. Calibration Description.** TI parameters and performance specifications which pertain to this calibration are listed in table 1.

Table 1. Calibration Description

Test instrument parameters	Performance specifications
Frequency	Range: $\leq 11$ to $\geq 13.5$ MHz at AM FM/32 output $\leq 88$ to $\geq 108$ MHz at FM/4 output $\leq 352$ to $\geq 432$ MHz at FM output
FM distortion	$< 0.025\%$ THD (total harmonic distortion)
FM linearity	Range: 399.6 and 400.4 MHz Accuracy: $\pm 2$ mV rms
FM flatness	Range: dc to 100 kHz rates Accuracy: $\pm 0.1\%$ Range: dc to 200 kHz rates Accuracy: $\pm 0.25\%$

## SECTION II EQUIPMENT REQUIREMENTS

**4. Equipment Required.** Table 2 identifies the specific equipment to be used in this calibration procedure. This equipment is issued with Secondary Reference Calibration Standards Set, NSN 4931-00-621-7878. Alternate items may be used by the calibrating activity. The items selected must be verified to perform satisfactorily prior to use and must bear evidence of current calibration. The equipment must meet or exceed the minimum use specifications listed in table 2. The accuracies listed in table 2 provide a four-to-one ratio between the standard and TI. Where the four-to-one ratio cannot be met, the actual accuracy of the equipment selected is shown in parenthesis.

**5. Accessories Required.** The accessories required for this calibration are common usage accessories, issued as indicated in paragraph 4 above, and are not listed in this calibration procedure. The following peculiar accessory is also required for this calibration: Frequency Doubler, Hewlett Packard, Model 11690A.

Table 2. Minimum Specifications of Equipment Required

Common name	Minimum use specifications	Manufacturer and model (part number)
FUNCTION GENERATOR	Range: 10 kHz -20 to +7 dBm Flatness: ±1% Distortion: < - 60 dB	Agilent, Model 33250A (33250A)
MEASURING RECEIVER	Frequency Range: 9 to 450 MHz Accuracy: ±0.1 % Carrier frequency: 12 to 400 MHz Demodulation sensitivity: FM: 1 V/kHz AM: 1 V/10% Filters: 50 Hz, high pass 3 kHz low pass	Hewlett Packard, Model 8902A w/sensor, Hewlett Packard, Model 11722A (11722A)
MULTIMETER	Range: 0 to 10 V dc Accuracy: ±0.1% Range: 1.998 to 2.002 V ac Accuracy: 1%	Hewlett Packard, Model 3458A (3458A)
SPECTRUM ANALYZER	Range: 12 to 1600 MHz Relative power indication Accuracy: ±2 dB	(AN/USM-677)
THERMAL CONVERTER	Max input voltage: 1 V rms Accuracy: ±0.05%	Filmohm, Model B7842-2 (7913198-2)

### SECTION III CALIBRATION PROCESS

#### 6. Preliminary Instructions

**a.** The instructions outlined in paragraphs 6 and 7 are preparatory to the calibration process. Personnel should become familiar with the entire bulletin before beginning the calibration.

**b.** Items of equipment used in this procedure are referenced within the text by common name as listed in table 2.

**c.** Unless otherwise specified, verify the result of each test and, whenever the test requirement is not met, take corrective action before continuing with the calibration. Adjustments required to calibrate the TI are included in this procedure. Additional maintenance information is contained in the manufacturers' manual for this TI.

**d.** Unless otherwise specified, all controls and control settings refer to the TI.

**7. Equipment Setup**

Set **LINE** switch to **ON** and allow 30 minutes for warm-up.

**WARNING**

HIGH VOLTAGE is used or exposed during the performance of this calibration. DEATH ON CONTACT may result if personnel fail to observe safety precautions. REDUCE OUTPUT(S) to minimum after each step within the performance check where applicable.

**8. Frequency Range**

**a. Performance Check**

- (1) Set **TEST MODE** switch to **FM**.
- (2) Set measuring receiver to measure frequency and connect measuring receiver sensor to **TI FM OUTPUT**.
- (3) Rotate **CARRIER FREQUENCY TUNE** control from fully ccw through fully cw while observing measuring receiver indications. If measuring receiver does not indicate less than 352 MHz at low end and more than 432 MHz at high end, perform **b** below.
- (4) Connect measuring receiver sensor to **TI FM/4 OUTPUT**.
- (5) Repeat technique of (1) through (3) above for TI connections and switch positions listed in table 3. Measuring receiver will indicate within limits specified.

Table 3. Frequency Range

Test instrument		Measuring receiver indications (MHz)	
Connection (OUTPUT)	TEST MODE switch positions	Maximum for ccw	Minimum for cw
FM/4	FM	88	108
AM, FM/32	FM	11	13.5
AM, FM/32	AM	11	13.5

**b. Adjustments**

- (1) Connect multimeter to A1TP4 (fig. 1), and chassis ground.
- (2) Set **TEST MODE** switch to **AM** and adjust **CARRIER FREQUENCY TUNE** control for a -4.60 V dc indication on multimeter.
- (3) Unsolder loop A1L3 (fig. 1) and slide it in or out until measuring receiver indicates 400 MHz. Resolder loop A1L3 (fig. 1) (R).

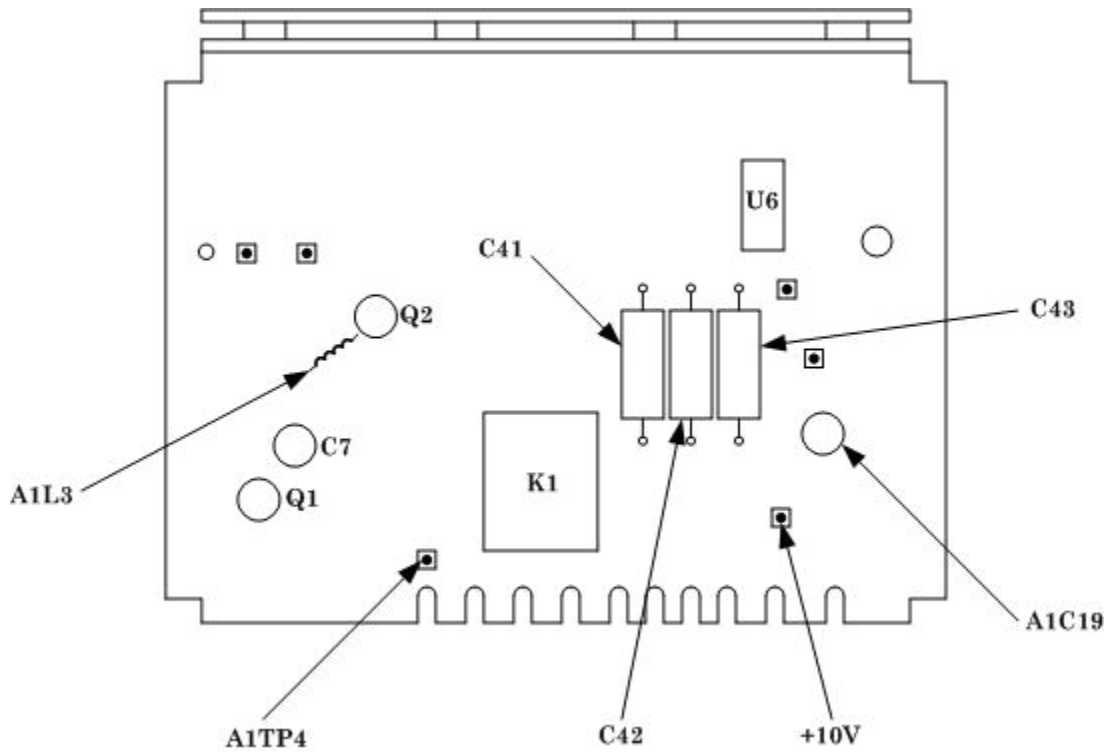

Figure 1. Calibration fixture - adjustment and test points.

## 9. FM Distortion

### a. Performance Check

- (1) Connect equipment as shown in figure 2.
- (2) Set TI **TEST MODE** switch to **FM**.
- (3) Set function generator controls for a 10 kHz, -18 dBm output.
- (4) Set measuring receiver to measure frequency in track tune mode.
- (5) Adjust TI **CARRIER FREQUENCY TUNE** until measuring receiver indicates  $400.000 \pm 0.010$  MHz.
- (6) Set measuring receiver controls to measure average FM with a 50 Hz high pass filter (low pass filters and **FM** de-emphasis off).
- (7) Adjust function generator amplitude for a 20 kHz indication on measuring receiver.

### NOTE

Perform (8) through (11) below quickly to minimize effects of TI carrier drift on measurement.

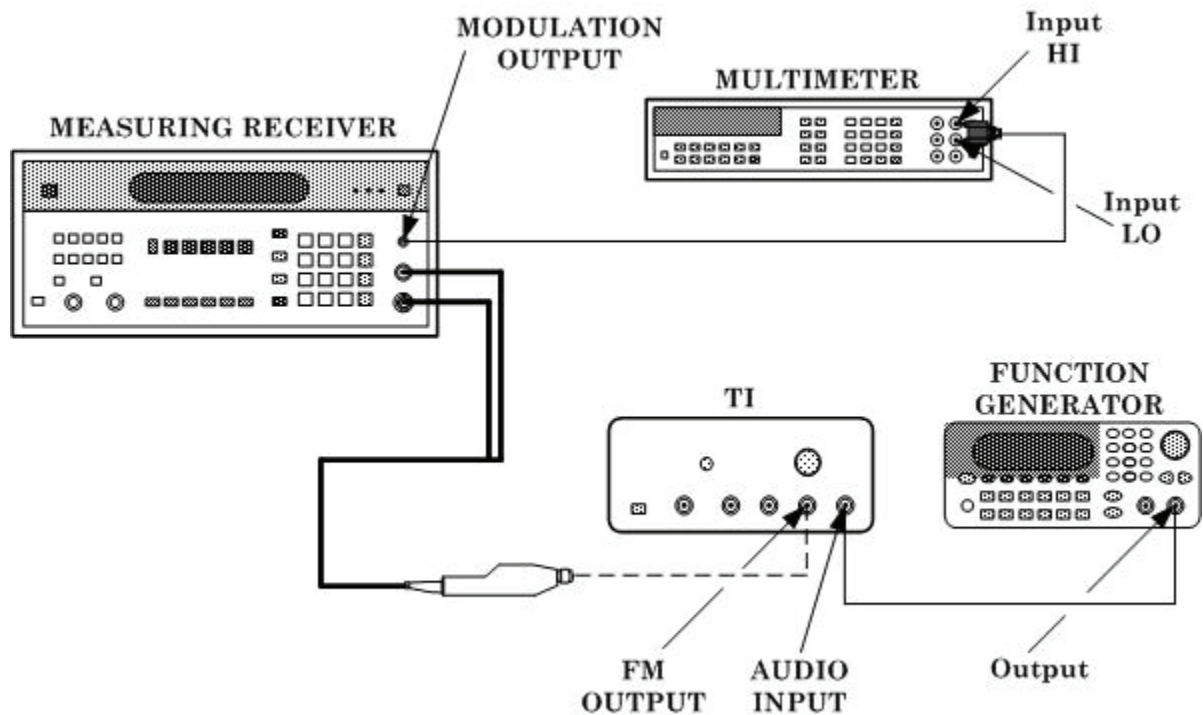

Figure 2. FM distortion - equipment setup.

(8) Set measuring receiver to measure frequency.

(9) Note ACV indication on multimeter or set reading as reference utilizing percent error feature.

**NOTE**

To utilize percent error feature on multimeter, set carrier frequency reference utilizing “SMATH” command, then utilize “MATH PERC” command to read percent error indications at desired low and high end points.

(10) Adjust TI **CARRIER FREQUENCY TUNE** until measuring receiver indicates  $400.400 \pm 0.010$  MHz. Multimeter will indicate within  $\pm 2$  mV ac of indication noted in (9) above or  $\pm 0.1\%$  error.

(11) Adjust TI **CARRIER FREQUENCY TUNE** until measuring receiver indicates  $399.600 \pm 0.010$  MHz. Multimeter will indicate within  $\pm 2$  mV ac of indication noted in (9) above or  $\pm 0.1\%$  error.

**b. Adjustments.** No adjustments can be made.

**10. FM Flatness**

**a. Performance Check**

(1) Connect equipment as shown in figure 3, CONNECTION A.

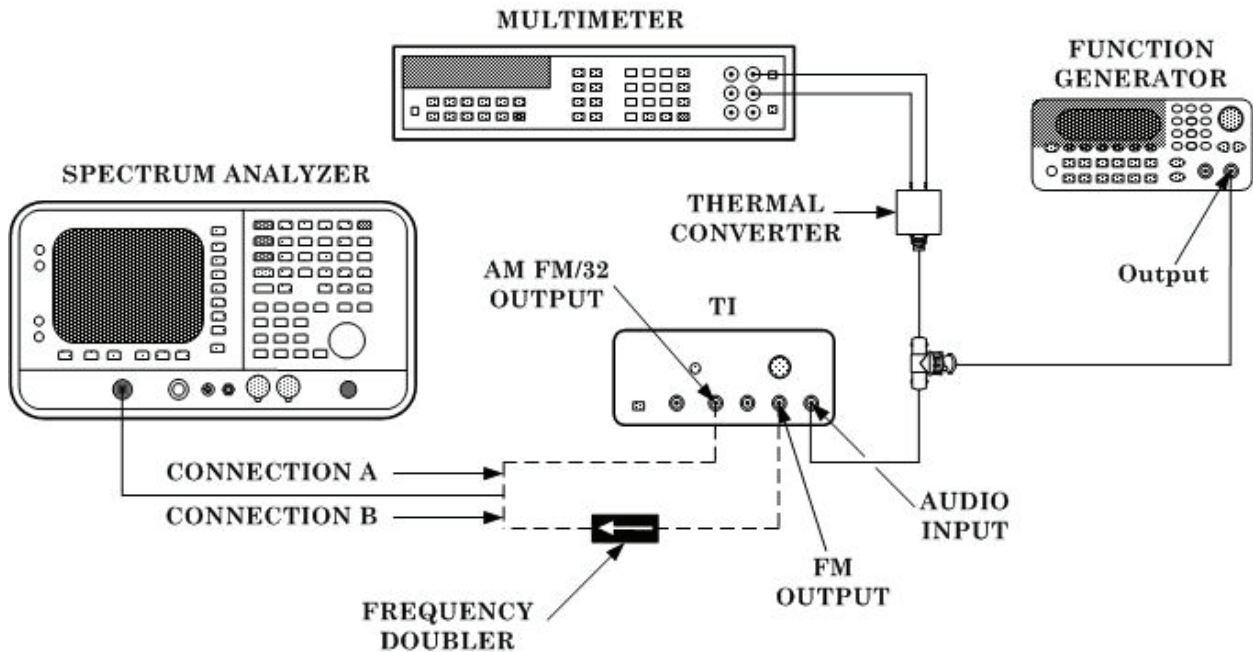

Figure 3. FM flatness - equipment setup.

**CAUTION**

Ensure that limits of thermal converter are not exceeded.

- (2) Set function generator controls for a 5 kHz, + 7 dBm output.
- (3) Set TI **TEST MODE** switch to **FM** and **CARRIER FREQUENCY TUNE** to 12.5 MHz (default reading from setup in previous test). If in doubt, initially verify this frequency output).
- (4) Set spectrum analyzer to measure the 12.5 MHz carrier frequency utilizing optimum settings for a display of carrier frequency as shown in figure 4.
- (5) Momentarily disconnect TI **AUDIO INPUT** and adjust spectrum analyzer reference level for full screen deflection of the carrier signal. Reconnect **AUDIO INPUT**.

**NOTE**

Perform (6) through (12) below as quickly as possible to avoid any effects caused by drift.

- (6) Adjust function generator output level until the spectrum analyzer indicates the TI carrier signal nulls into noise baseline as shown in figure 4. (The level should be adjusted so that the TI signal null is half way between the two levels at which the carrier comes out of the noise.)

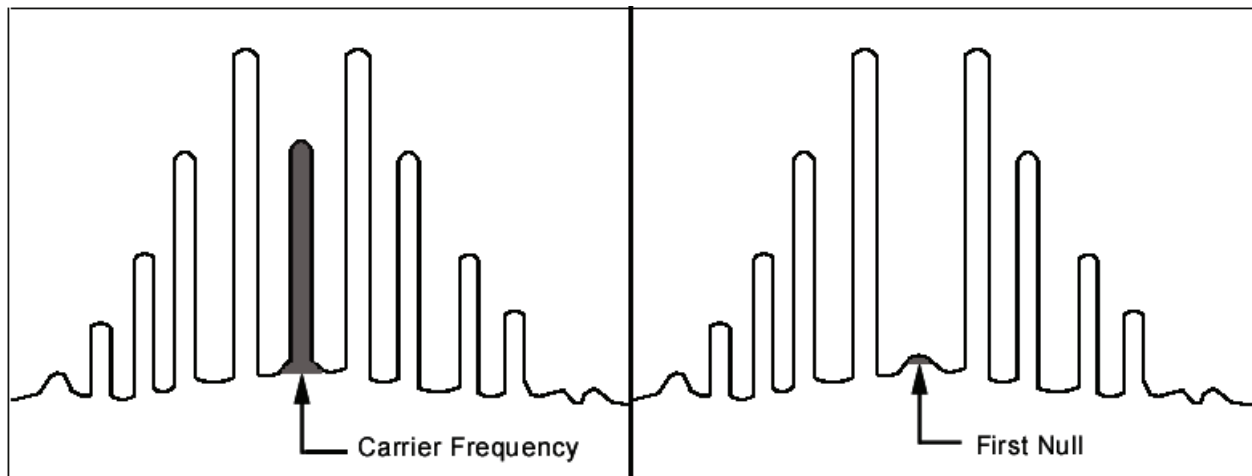

Figure 4. First carrier null of carrier frequency.

- (7) Note multimeter dc V indication.
- (8) Set function generator frequency to 640 kHz.
- (9) Connect equipment as shown in figure 3, CONNECTION B, using frequency doubler.
- (10) Adjust spectrum analyzer until the second harmonic of the doubled carrier frequency signal (approximately 1600 MHz) can be observed. Again, use optimum settings for a display as shown in figure 4.
- (11) Adjust function generator output level until multimeter indicates value noted in (7) above. Note function generator output level dBm setting.
- (12) Readjust function generator output level for a carrier null on spectrum analyzer, as shown in figure 4, and note change in function generator output dBm level. Level change will be less than  $\pm 0.04$  dBm of output level noted in (11) above.

**b. Adjustments.** No adjustments can be made.

## 11. Final Procedure

- a.** Deenergize and disconnect all equipment.
- b.** Annotate and affix DA label/form in accordance with TB 750-25.



By Order of the Secretary of the Army:

Official:



JOYCE E. MORROW  
*Administrative Assistant to the  
Secretary of the Army*

GEORGE W. CASEY, JR.  
*General, United States Army  
Chief of Staff*

0804603

Distribution:

To be distributed in accordance with STD IDS No. RLC-1500, 2 January 2003, requirements for calibration procedure TB 9-4931-527-40.



### Instructions for Submitting an Electronic 2028

The following format must be used if submitting an electronic 2028. The subject line must be exactly the same and all fields must be included; however, only the following fields are mandatory: 1, 3, 4, 5, 6, 7, 8, 9, 10, 13, 15, 16, 17, and 27.

From: "Whomever" [whomever@redstone.army.mil](mailto:whomever@redstone.army.mil)  
To: <2028@redstone.army.mil

Subject: DA Form 2028

1. **From:** Joe Smith
2. **Unit:** home
3. **Address:** 4300 Park
4. **City:** Hometown
5. **St:** MO
6. **Zip:** 77777
7. **Date Sent:** 19-OCT-93
8. **Pub no:** 55-2840-229-23
9. **Pub Title:** TM
10. **Publication Date:** 04-JUL-85
11. **Change Number:** 7
12. **Submitter Rank:** MSG
13. **Submitter FName:** Joe
14. **Submitter MName:** T
15. **Submitter LName:** Smith
16. **Submitter Phone:** 123-123-1234
17. **Problem:** 1
18. **Page:** 2
19. **Paragraph:** 3
20. **Line:** 4
21. **NSN:** 5
22. **Reference:** 6
23. **Figure:** 7
24. **Table:** 8
25. **Item:** 9
26. **Total:** 123
27. **Text**

This is the text for the problem below line 27.





